

PHARMACEUTICAL INDUSTRY



Rieckermann Services (Jordan) Ltd.

Mr. Ahmad Jarwan
Sales Supervisor

Abdullah Ghosheh Street, Grand City 1, No. 38
Office No. 504, Amman 11195, Jordan
Phone: +962 658 524 00
Email: a.jarwan@rieckermann.com

We look forward to hearing from you and meeting you in person.

Please find all addresses and contact information for local offices on our website: www.rieckermann.com

360° CUSTOMIZED INDUSTRIAL SOLUTIONS

Rieckermann provides consulting and engineering, state-of-the-art machinery, and technical services for several industries. With 130 years of experience, our international team of experts and local representatives in Asia and the Middle East deliver customized high-quality solutions along the whole value chain of industrial production and processes.

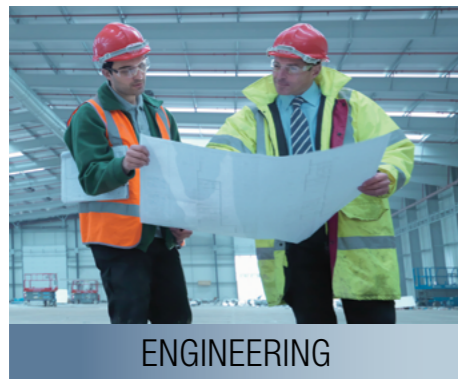

ENGINEERING

Rieckermann consulting & engineering solutions

- Site master planning, feasibility studies & conceptual design
- Engineering & design
- Procurement
- Construction management
- Commissioning, validation & training
- EU GMP compliance services



MACHINERY

Rieckermann process technology

- Machinery & industrial equipment
- Machinery procurement & contracting
- Global trade finance
- Commercial licensing & consulting
- Consumables & raw materials



TECHNICAL SERVICES

Rieckermann technical services

- FAT/SAT
- Local content management
- Installation & calibration
- Training & local language support
- After sales service & maintenance
- Spare parts

OUR FULL-SERVICE APPROACH

Our Solution Circle gives you an overview of how we can support you to develop, build, and improve your industrial production and processes. Our services and technology can be flexibly combined to best match your individual needs – from consultancy, concept design, and equipment supply, to the full scope or any combination of project services.

Rieckermann project management

- Integrated planning & consulting
- Global trade finance
- Full scope expertise & interface handling
- Experience with local conditions & international standards
- Lifelong service & support

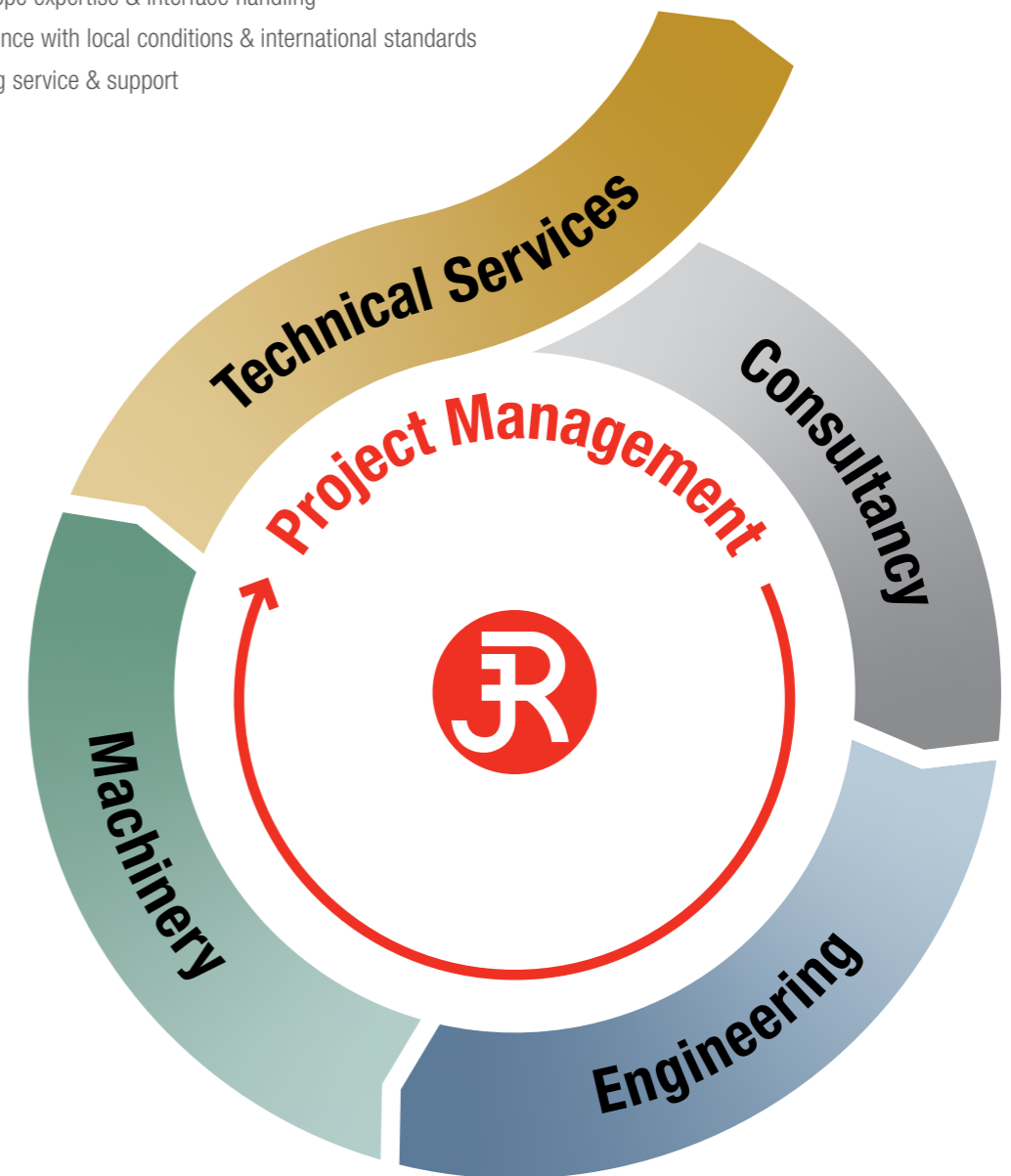

PHARMA INDUSTRY SOLUTIONS BY RIECKERMANN

Rieckermann has been providing support for the pharmaceutical industry for decades, with solutions and services for the processing, production, and packaging of all types of pharmaceuticals in liquid, solid, or semi-solid form. Furthermore, we serve clients who produce active pharmaceutical ingredients, medical devices, and cosmetics.

We continuously strive to expand our knowledge of pharmaceutical trends in different countries. This enables us to provide local solutions in line with international regulatory standards. When it comes to our engineering services, we offer expert advice on implementing good manufacturing practice (GMP) and ensuring PIC/S compliancy for virtually every pharmaceutical application.

Profit from the extensive know-how of our international network of experts and partners – and get access to the latest innovations.

Solid processing & packaging solutions



Liquid processing & packaging solutions



Semi solid processing & packaging solutions



Auxiliary equipment & commodities



Medical devices & combination products



LIQUID PROCESSING & PACKAGING SOLUTIONS

Rieckermann's liquid processing and packaging solutions include equipment for the whole range of processes – from the production of pharmaceutical liquids through to downstream, including primary packaging, such as the filling and closing of containers, and secondary packaging.

We know the challenges you face: sterility issues, interface clarification of up and downstream equipment, or packaging material quality, and development. Our experts understand your individual requirements and can provide you with the ideal solution from our broad portfolio.

Profit from our wide portfolio for liquid solutions

- Purified water systems & water for injection production
- Preparation systems for syrups, suspensions & injectables
- Distribution loops & CIP / SIP systems
- Washing, sterilizing, filling & closing, labeling/serialization of ampoules, cartridges, syringes, vials & bottles
- Blow-fill-seal (BFS) equipment for SVP / LVP
- Autoclaves
- Lyophilizers
- Rubber-stopper washing/sterilizing
- Open/closed RABS & isolators
- Non-sterile equipment
- Inspection systems
- Biowaste decontamination systems
- Packaging materials
- Laboratory equipment

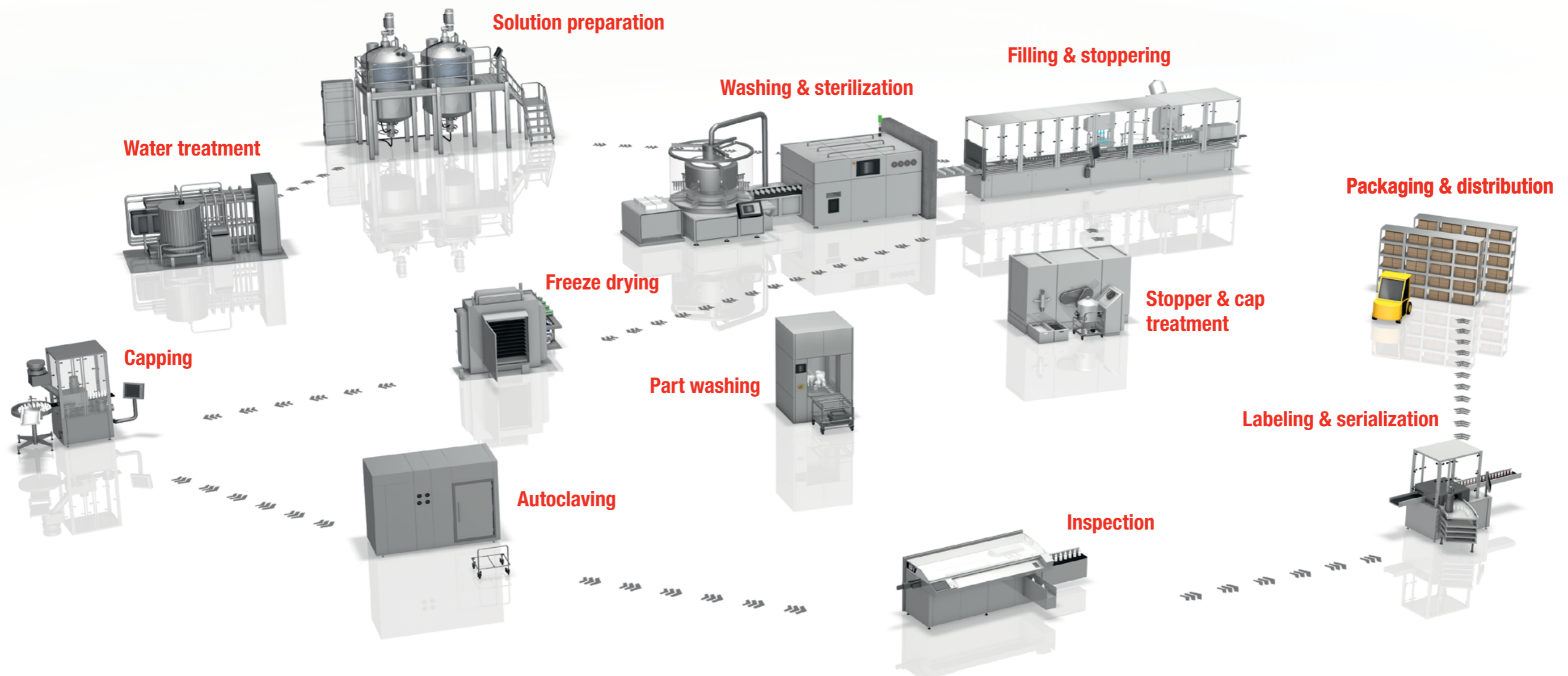

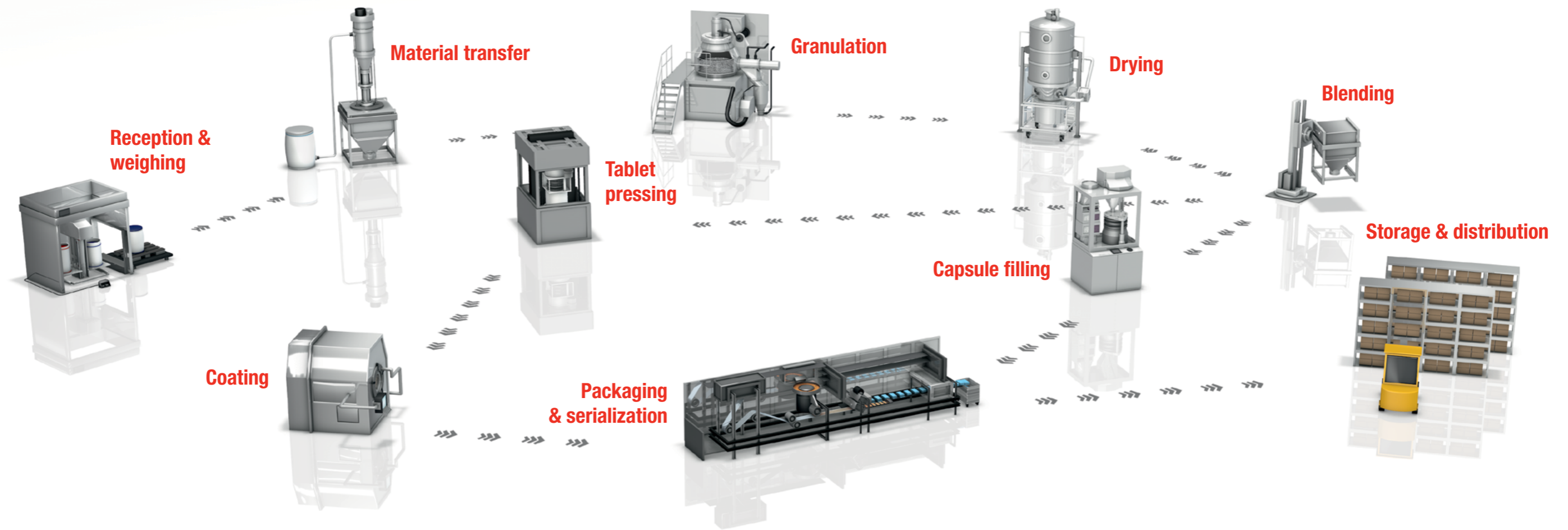

SOLID PROCESSING & PACKAGING SOLUTIONS

The production of solid pharmaceuticals requires technologies assuring dust-free handling, a uniform, and homogenous mixing of active ingredients into carrier materials as well as the supervision of critical process parameters to achieve a continuously high level of product quality.

This is why we always focus on optimal workflows, cost-efficiency, and safety with every piece of equipment. From laboratories to pilot and production plants, we provide a dedicated solution for all your requirements.

Benefit from our portfolio for solid solutions

- Mixers & blenders
- Fluid bed dryers/granulators
- Wet & dry size reduction mills
- Compactors
- Powder-handling equipment
- Tablet presses
- Powder, pellet & tablet coating
- Powder-fillers & capsule fillers
- Blister machines, cartoners & serialization
- Tablet/capsule counting lines
- Containment solutions
- Packaging materials
- Laboratory equipment

**FOR IDEAL PROCESSES OF ALL APPLICATIONS
FROM A SINGLE SOURCE**

SEMI SOLID PROCESSING & PACKAGING SOLUTIONS

Together with our global leading partners, we provide you with ideal solutions for sterile and non-sterile pharmaceutical applications – from creams and ointments to suppositories and soft gelatin capsules.

Whether you are in the life science, healthcare, or cosmetic industry, we provide a full-service approach, supporting your business with the entire downstream packaging process into tubes, jars, bottles, or blisters.

Discover our range of semi-solid solutions

- Mixers & homogenizers
- Tube filling & cartoning
- Suppository filling & packing
- Soft gelatin processing & filling equipment

AUXILIARY EQUIPMENT & COMMODITIES

Auxiliaries are part of every industrial solution and can have a major impact on the productivity of the whole process. Thanks to our longstanding experience, we understand the essential details of your production process and integrate smooth interfaces both up and downstream.

Our range of auxiliaries contains countless components and periphery equipment to enable lean and seamless production.

Explore our range of auxiliary equipment & commodities

- Lab testing equipment
- Check weighers & metal checkers
- Glass forming, annealing & siliconization machineries for cartridges, syringes & vials
- Glassware, rubber stoppers & aluminum caps
- Aluminum & plastic foils
- Resin
- Etc.

MEDICAL DEVICES & COMBINATION PRODUCTS

Medical devices are used to administer treatments for patients and are therefore subject to the highest hygiene, safety, and accuracy requirements.

We provide you with solutions for your medical device production and assembly, as well as for your packing and post-sterilization applications.

Explore our spectrum of medical devices & combination products

- Assembly equipment for giving sets, catheters, inhalers, pens & syringes
- Hemodialyzer assembly lines
- Manufacturing of bloodbag systems
- Plaster & oral strip processing lines
- Etc.



CUSTOMIZED PHARMACEUTICAL SOLUTIONS

For any specific requirements you may have, we can deliver customized solutions to help ensure smooth operations and accurate results for you.

- Insulin filling lines and parallel procurement of all necessary sample materials, including registration of the packing materials in the end-user's country.
- High-speed inspections, labeling, and end packing lines for cartridges, including project management and coordination of suppliers.
- Syringe processing lines for COVID-19 vaccination (forming & annealing), including cannula insertion, washing, siliconizing, shielding, nesting, and packing from a single source, with complete project coordination and including procurement of non-existing sample material.
- Turn-key granulation lines, comprising mixer, FB dryer, coater, container washer, WIP system, container blender and blistering, with integration of local content such as air duct, working platform, piping, installation, commissioning, and IQ / OQ support.
- Health-drink lines comprising BFS, leak detection, capping, and labeling as well as special end packing.
- Plaster production lines comprising coating, slicing, stacking, packing, and end packing, with complete project management, transfer of sample material, and coordination of single shipments.
- Turn-key factories for injectables (liquid & lyo), including water purification, loops, filling lines, autoclaves, and complete clean rooms.
- Tablet production lines, including pneumatic or drum feeding of granulate, metal check, dedusting, and transfer to packing line (tubes or blisters).
- Oncology production lines, including vial filling line for lyo products with transfer to freeze dryer and subsequent outside washing, all under isolator and including dry-solids processing as well as packing equipment.

PROJECT HIGHLIGHTS



Quick response for urgent machinery delivery

In response to an urgent machinery order required to meet vaccine demands during the height of the pandemic, Rieckermann proactively chartered a flight to ensure that the shipment from Hamburg to China was concluded in less than 24 hours. Our experts and technical engineers were on hand to ensure that the entire transport process, relevant installation, and acceptance procedures were completed within only three days.



[Read more](#)



Rieckermann designs Vietnam's first mRNA Covid-19 vaccine production facility

The largest conglomerate in Vietnam has established a manufacturing facility in Hanoi to produce mRNA COVID-19 vaccines. A fast-track project was needed to contribute to Vietnam's fight against COVID-19. Rieckermann delivered design, project management, and GMP management services for this ambitious project in time to market.



[Read more](#)



Challenges of travel restrictions tackled by local technical support

To achieve a high level of accuracy in all production phases, Rieckermann's local experts assisted a major client with installing, commissioning, testing, and qualifying a process line for the mass production of Molnupiravir, a low-cost antiviral medication. Rieckermann's local service engineers were able to follow up on all technical service requests on behalf of the technology partner as Vietnam has had its borders closed for nearly two years due to the pandemic.



[Read more](#)

RIECKERMANN TECHNICAL SERVICES



Installation of your machines has never been easier.

With a pool of over 150 highly skilled and well trained, full time employed service engineers, we will always ensure the installation of your machine is up to the highest technical standards as well as in line with local regulations and requirements.

You can choose from anywhere between professional installation assistance through expert supervision to full turn-key installation of your equipment. All engineers assigned to you can communicate in the local language as well as fluently in technical English.

The high level of experience and number of specialist trainings our engineers receive further ensure the smooth and reliable operation of your project with all of the important steps taken care of by the Rieckermann Technical Service Division.

Our technical services range

- Installation of automation hardware & software
- Hookup of supply media (pressure, water & electricity)
- Installation supervision - electrical & mechanical
- Calibration
- Commissioning & execution of SAT
- Training & start-up support
- Maintenance & spare parts

**MAXIMIZING YOUR PROFITABILITY
BY MINIMIZING MACHINE DOWNTIME**



750 EMPLOYEES
150 SERVICE ENGINEERS
24 OFFICES
17 COUNTRIES

Your local Rieckermann office is right around the corner from you. Our local team is ready to find the best solution for your business.

We look forward to hearing from you and meeting you in person. Please find all addresses and contact information for local offices on our website:
www.riekermann.com